



The Power of Reliability™

EPRI PEAC Corporation

A Power Quality Engineering Services Company

SEMI F47 Compliance Certificate EPRI PEAC Corporation PQ Starsm Test Program Certification Date: May 3rd, 2002

PQ Starsm Reference Number
SEMIF47.040

Manufacturer: Schneider Electric

Product: Telemecanique
Altivar 58 Series Drives

Test Date(s):
February 6, 2002 – April 3rd, 2002

Test Location:
EPRI PEAC Corporation
942 Corridor Park Blvd
Knoxville, TN 37932

Test Configuration: The drives were tested using EPRI PEAC's drive test stand with a SEMI F42 compliant voltage sag generator. All drive settings were set to default except for those needed to setup for motor and the following: Input phase loss set to "No", and Catch on Fly set to "Yes", Cont Stop set to "NMS". In order for drive to restart, the drive must be setup for 2-wire control and the start signal remain during sag.

Electrical Environment:
400Vac, 50Hz
(See Attachments A, B, C, & D for detailed results and Test Protocol)

Model Numbers and Load Configurations Tested

Model#	Version	Drive Specs	HP VT	HP CT
ATV58HU72N4ZU	V3.1 IE14	4kW/5HP - 400/460V - 50/60Hz	7.5	5
ATV58HU90N4ZU	V3.1 IE14	5.5kW/7.5HP - 400/460V - 50/60Hz	10	7.5
ATV58HD12N4ZX	V3.1 IE14	7.5kW/10HP - 400/460V - 50/60Hz	15	10
ATV58HD16N4ZX	V3.1 IE14	11kW/15HP - 400/460V - 50/60Hz	20	15
ATV58HD23N4ZX	V3.1 IE14	15kW/20HP - 400/460V - 50/60Hz	25	
ATV58HD23N4ZX	V4.1 IE25	15kW/20HP - 400/460V - 50/60Hz	25	
ATV58HD28N4XZX	V3.1 IE14	18.5kW/25HP - 400/460V - 50/60Hz	30	
ATV58HD33N4XZX	V4.1 IE25	22kW/30HP - 400/460V - 50/60Hz	40	
ATV58HD46N4XZX	V3.1 IE14	30kW/40HP - 400/460V - 50/60Hz	50	
ATV58HD54N4XZ	V4.1 IE25	37kW/50HP - 400/460V - 50/60Hz	60	

This letter and subsequent documentation certifies that specified Altivar 58 drives in the noted configuration have been voltage sag tested per SEMI F42 test protocol and was found to comply to the SEMI F47 voltage sag immunity standard. Based on these results, it is expected that the entire line is compliant with SEMI F47. This certification remains valid to the model tested only and as long as no component substitutions are made.

Certified by,

Alden E. Wright
PQ Star Certification Engineer



Altivar 58 Series Drives



Attachment A – SEMI F47 Test Results

Testing was performed at EPRI PEAC’s Power Quality Laboratory in Knoxville, TN. The test protocol followed was based on SEMI F42 “Test Method for Semiconductor Processing Equipment Voltage Sag Immunity”. The test protocol is attached to this document. The drives were tested using a dynamic dynamometer or an eddy current brake to provide constant torque (CT) and/or variable torque (VT) based on horsepower rating according to Table A-1.

Table A-1. Test Load Scheme

	HP VT	HP CT
Dynamic Dynamometer (Figure B-1)	7.5	5
	10	7.5
	15	10
	20	15
Eddy Current Brake (Figure B-2)	25	
	25	
	30	
	40	
	50	
	60	

In order for drive to restart the drive must be setup for 2-wire control and the start signal remain during sag. All drive settings were set to default except for those needed for motor setup and the following:

- Input phase loss set to "No"
- Catch on Fly set to "Yes"
- Cont.Stop set to "NMS"



The data obtained from each test was organized in a table as illustrated in Figure A-1.

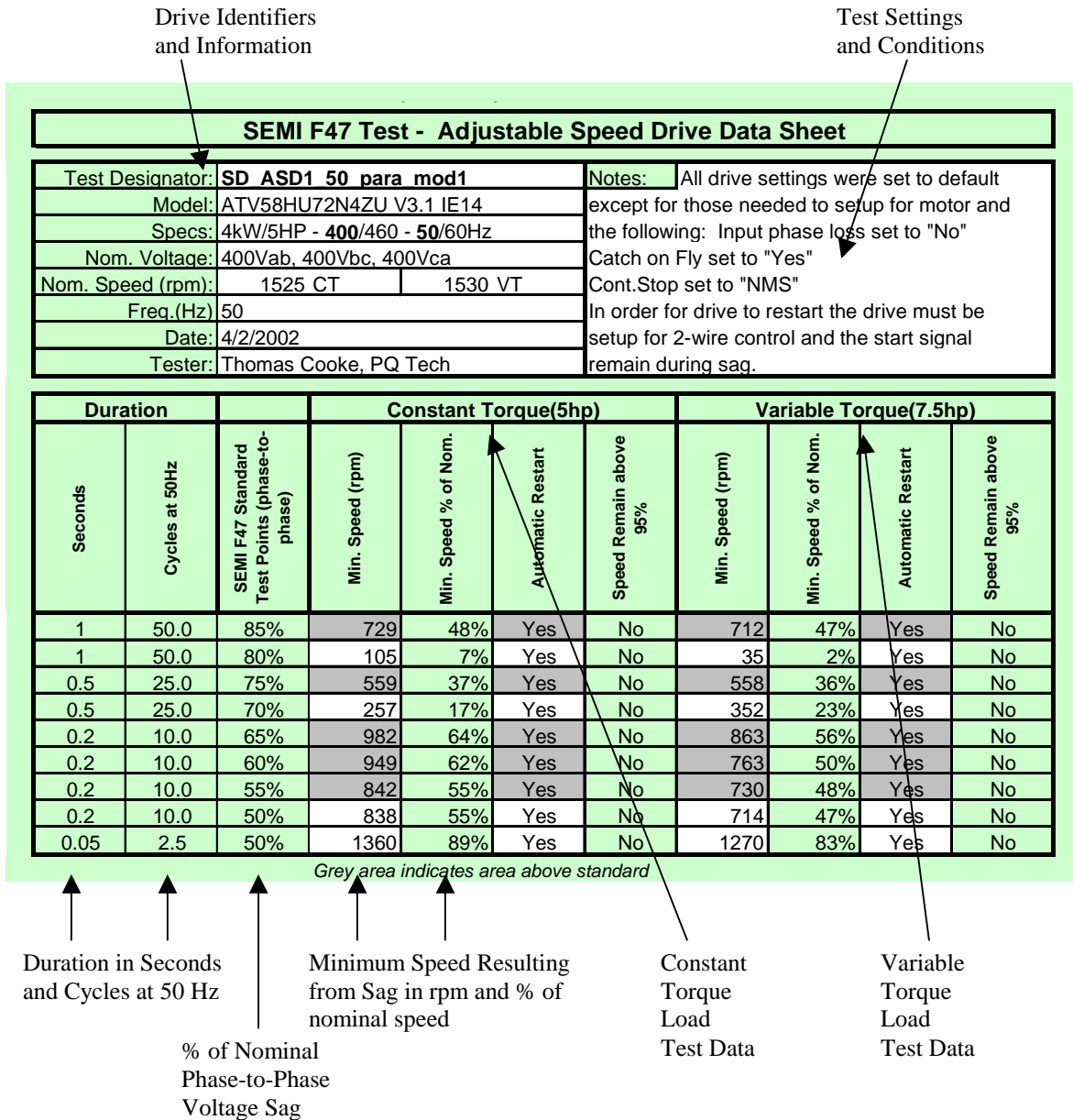

Figure A-1. Test Data Tables



Graphs illustrate the real-time effects of voltage sags on bus voltage and motor speed:

Test Condition
50% phase-to-phase
for 2.5 Cycles
(at 50Hz)

50%-2.5
Contant Torque (5hp)

Drive Full Load
Horse Power at either
Constant Torque or
Variable Torque

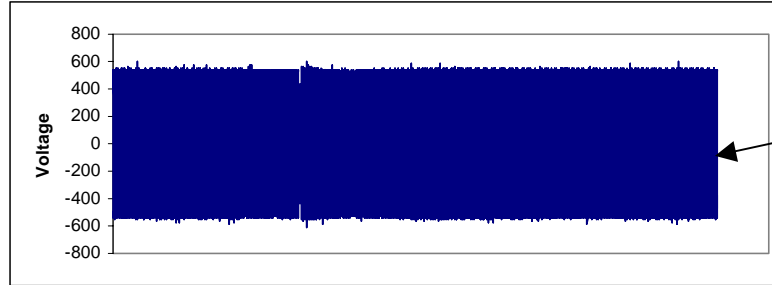

Voltage Sag

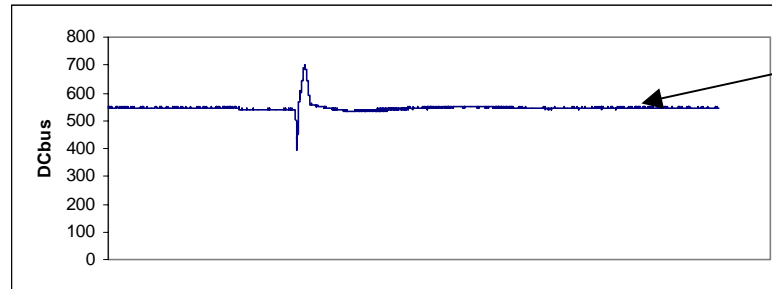

Drive DC
Bus

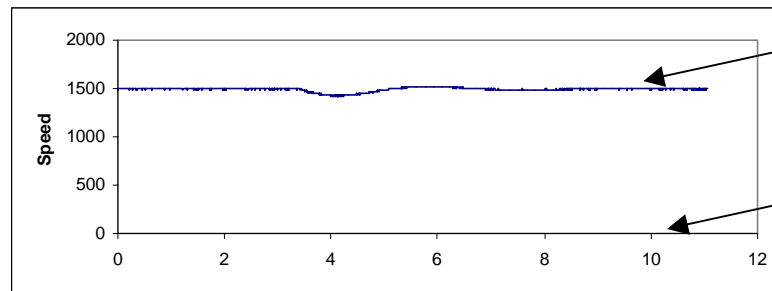

Motor
Speed

Time Scale
In Seconds



Representative Voltage Sag Test Data

**Table A-1: Example Tabular Test Results for 5HP Altivar Model
ATV58HU72N4ZU**

SEMI F47 Test - Adjustable Speed Drive Data Sheet											
Test Designator:	SD_ASD1_50_para_mod1					Notes:	All drive settings were set to default except for those needed to setup for motor and the following: Input phase loss set to "No" Catch on Fly set to "Yes" Cont.Stop set to "NMS" In order for drive to restart the drive must be setup for 2-wire control and the start signal remain during sag.				
Model:	ATV58HU72N4ZU V3.1 IE14										
Specs:	4kW/5HP - 400/460 - 50/60Hz										
Nom. Voltage:	400Vab, 400Vbc, 400Vca										
Nom. Speed (rpm):	1525 CT				1530 VT						
Freq.(Hz)	50										
Date:	4/2/2002										
Tester:	Thomas Cooke, PQ Tech										
Sec.	Duration Cycles 50Hz	SEMI F47 Standard Test Points	Constant Torque(5hp)				Variable Torque(7.5hp)				
			Min. Speed (rpm)	Min. Speed % of Nom.	Automatic Restart	Speed Remain above 95%	Min. Speed (rpm)	Min. Speed % of Nom.	Automatic Restart	Speed Remain above 95%	
1	50.0	85%	729	48%	Yes	No	712	47%	Yes	No	
1	50.0	80%	105	7%	Yes	No	35	2%	Yes	No	
0.5	25.0	75%	559	37%	Yes	No	558	36%	Yes	No	
0.5	25.0	70%	257	17%	Yes	No	352	23%	Yes	No	
0.2	10.0	65%	982	64%	Yes	No	863	56%	Yes	No	
0.2	10.0	60%	949	62%	Yes	No	763	50%	Yes	No	
0.2	10.0	55%	842	55%	Yes	No	730	48%	Yes	No	
0.2	10.0	50%	838	55%	Yes	No	714	47%	Yes	No	
0.05	2.5	50%	1360	89%	Yes	No	1270	83%	Yes	No	

Grey area indicates area above standard



**Figure A-1: Example Graphical Test Results for 5HP Altivar Model
ATV58HU72N4ZU**

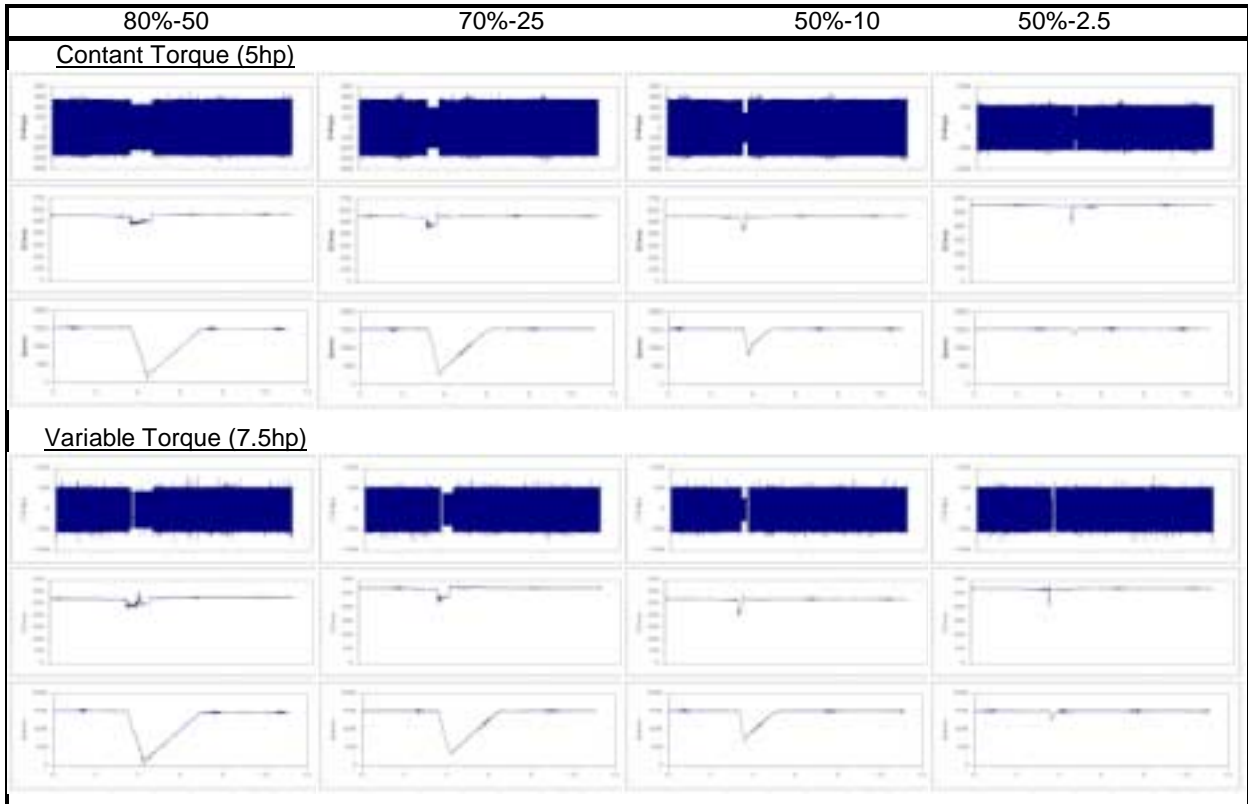



**Table A-2: Example Tabular Test Results for 20HP Altivar Model
ATV58HD23N4ZX**

SEMI F47 Test - Adjustable Speed Drive Data Sheet											
Test Designator:		SD_ASD6_50_para_mod1					Notes:				All drive settings were set to default except for those needed to setup for motor and the following: Input phase loss set to "No" Catch on Fly set to "Yes" Cont.Stop set to "NMS" In order for drive to restart the drive must be setup for 2-wire control and the start signal remain during sag.
Model:		ATV58HD23N4ZX V4.1 IE25									
Specs:		15kW/20HP - 400/460 - 50/60Hz									
Nom. Voltage:		400Vab, 400Vbc, 400Vca									
Nom. Speed (rpm):		No Test CT			1495 VT						
Freq.(Hz)		50									
Date:		2/11/2002									
Tester:		Thomas Cooke, PQ Tech									
Duration		Constant Torque(20hp)					Variable Torque(25hp)				
Sec.	Cycles 50Hz	SEMI F47 Standard Test Points	Min. Speed (rpm)	Min. Speed % of Nom.	Automatic Restart	Speed Remain above 95%	Min. Speed (rpm)	Min. Speed % of Nom.	Automatic Restart	Speed Remain above 95%	
1	50.0	80%	No Test	#VALUE!	No Test	#VALUE!	1362	91%	Yes	No	
0.5	25.0	70%	No Test	#VALUE!	No Test	#VALUE!	1390	93%	Yes	No	
0.2	10.0	65%	No Test	#VALUE!	No Test	#VALUE!	1428	96%	Yes	Yes	
0.2	10.0	60%	No Test	#VALUE!	No Test	#VALUE!	1422	95%	Yes	Yes	
0.2	10.0	55%	No Test	#VALUE!	No Test	#VALUE!	1430	96%	Yes	Yes	
0.2	10.0	50%	No Test	#VALUE!	No Test	#VALUE!	1420	95%	Yes	Yes	
0.05	2.5	50%	No Test	#VALUE!	No Test	#VALUE!	1420	95%	Yes	Yes	

Grey area indicates area above standard



The Power of Reliability™

EPRI PEAC Corporation

A Power Quality Engineering Services Company

**Figure A-2: Example Graphical Test Results for 20HP Altivar Model
ATV58HD23N4ZX**

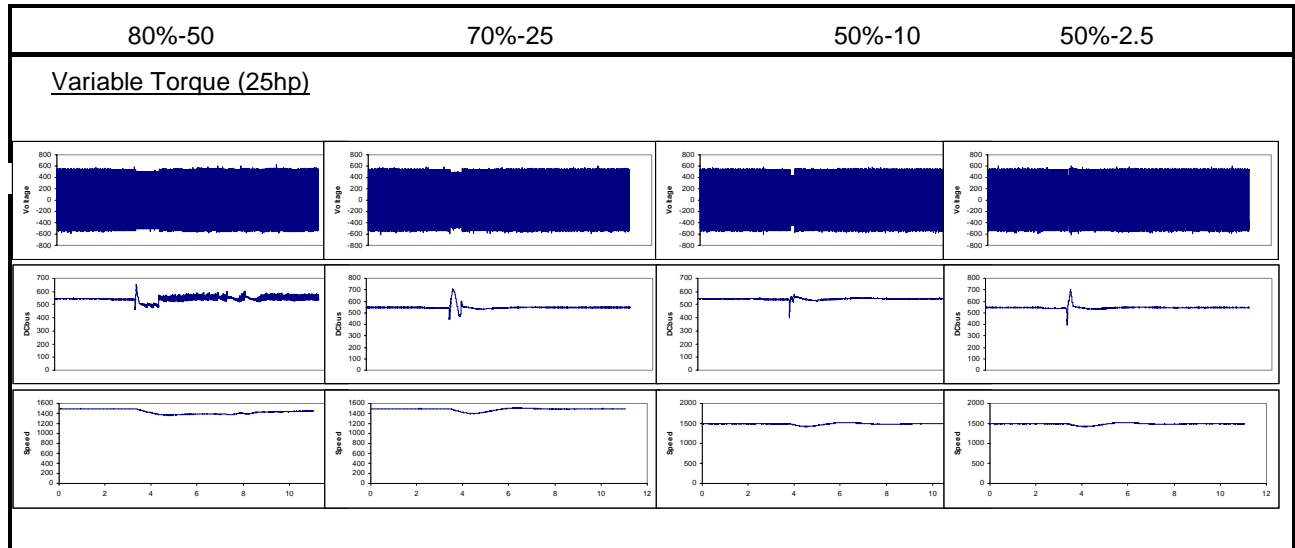



**Table A-3: Example Tabular Test Results for 50Hp Altivar Model
ATV58HD54N4XZ**

SEMI F47 Test - Adjustable Speed Drive Data Sheet										
Test Designator:		SD_ASD10_50_para_mod1				Notes:				
Model:		ATV58HD54N4XZ V4.1 IE25				All drive settings were set to default except for those needed to setup for motor.				
Specs:		37kW/50HP - 400/460 - 50/60Hz				Input phase loss set to "No"				
Nom. Voltage:		400Vab, 400Vbc, 400Vca				Catch on Fly set to "Yes"				
Nom. Speed (rpm):		No Test CT		1480 VT		Cont.Stop set to "NMS"				
Freq.(Hz)		50				In order for drive to restart the drive must be setup for 2-wire control and the start signal remain during sag.				
Date:		4/3/2002								
Tester:		Thomas Cooke, PQ Tech								
Sec.	Cycles 50Hz	SEMI F47 Standard Test Points	Constant Torque(50hp)				Variable Torque(60hp)			
			Min. Speed (rpm)	Min. Speed % of Nom.	Automatic Restart	Speed Remain above 95%	Min. Speed (rpm)	Min. Speed % of Nom.	Automatic Restart	Speed Remain above 95%
1	50.0	85%	no test	#VALUE!	no test	#VALUE!	1069	72%	Yes	No
1	50.0	80%	no test	#VALUE!	no test	#VALUE!	1000	68%	Yes	No
0.5	25.0	75%	no test	#VALUE!	no test	#VALUE!	1231	83%	Yes	No
0.5	25.0	70%	no test	#VALUE!	no test	#VALUE!	1208	82%	Yes	No
0.2	10.0	65%	no test	#VALUE!	no test	#VALUE!	1348	91%	Yes	No
0.2	10.0	60%	no test	#VALUE!	no test	#VALUE!	1336	90%	Yes	No
0.2	10.0	55%	no test	#VALUE!	no test	#VALUE!	1346	91%	Yes	No
0.2	10.0	50%	no test	#VALUE!	no test	#VALUE!	1298	88%	Yes	No
0.05	2.5	50%	no test	#VALUE!	no test	#VALUE!	1418	96%	Yes	Yes

Grey area indicates area above standard



The Power of Reliability™

EPRI PEAC Corporation

A Power Quality Engineering Services Company

**Figure A-3: Example Graphical Test Results for 50HP Altivar Model
ATV58HD54N4XZ**

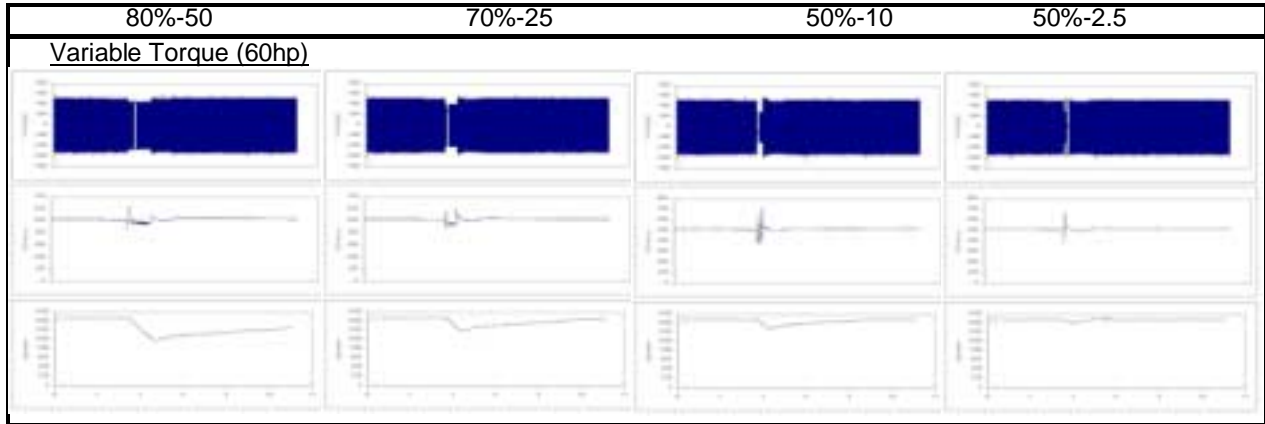

Attachment B - Test Configuration

Test Configuration

The SEMI F42 compliant voltage sag generator was placed in series with the main power feed, in accordance with SEMI F42 and shown in Figures B-1 and B-2. The Dynamic Dynamometer provides a constant torque or a variable torque load for motors rated at 20 HP or less. The eddy current brake provides a variable torque load for motors rated above 20 HP.

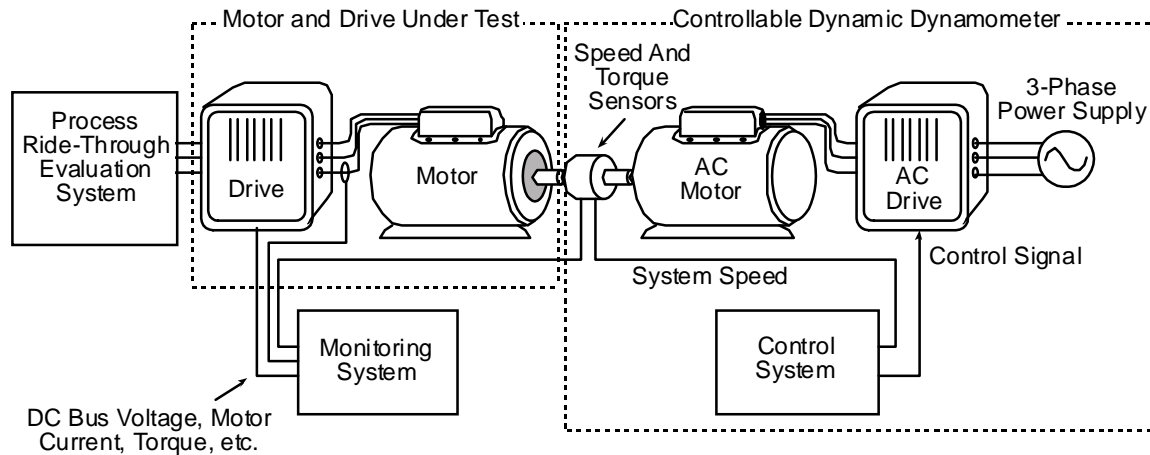

Figure B-1 – Test Configuration with Dynamic Dynamometer

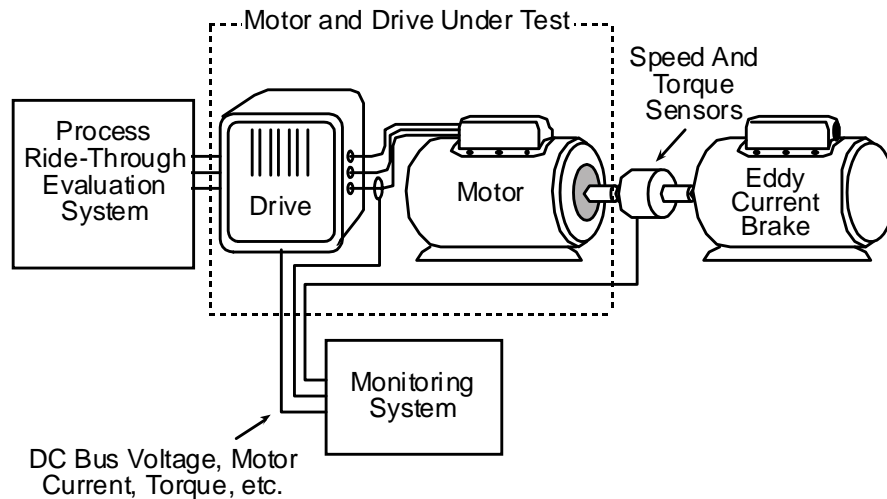

Figure B-2 – Test Configuration with Eddy Current Brake

The test facilities at EPRI PEAC and the specific equipment employed for testing the Altivar drives are shown below in Figure B-3.

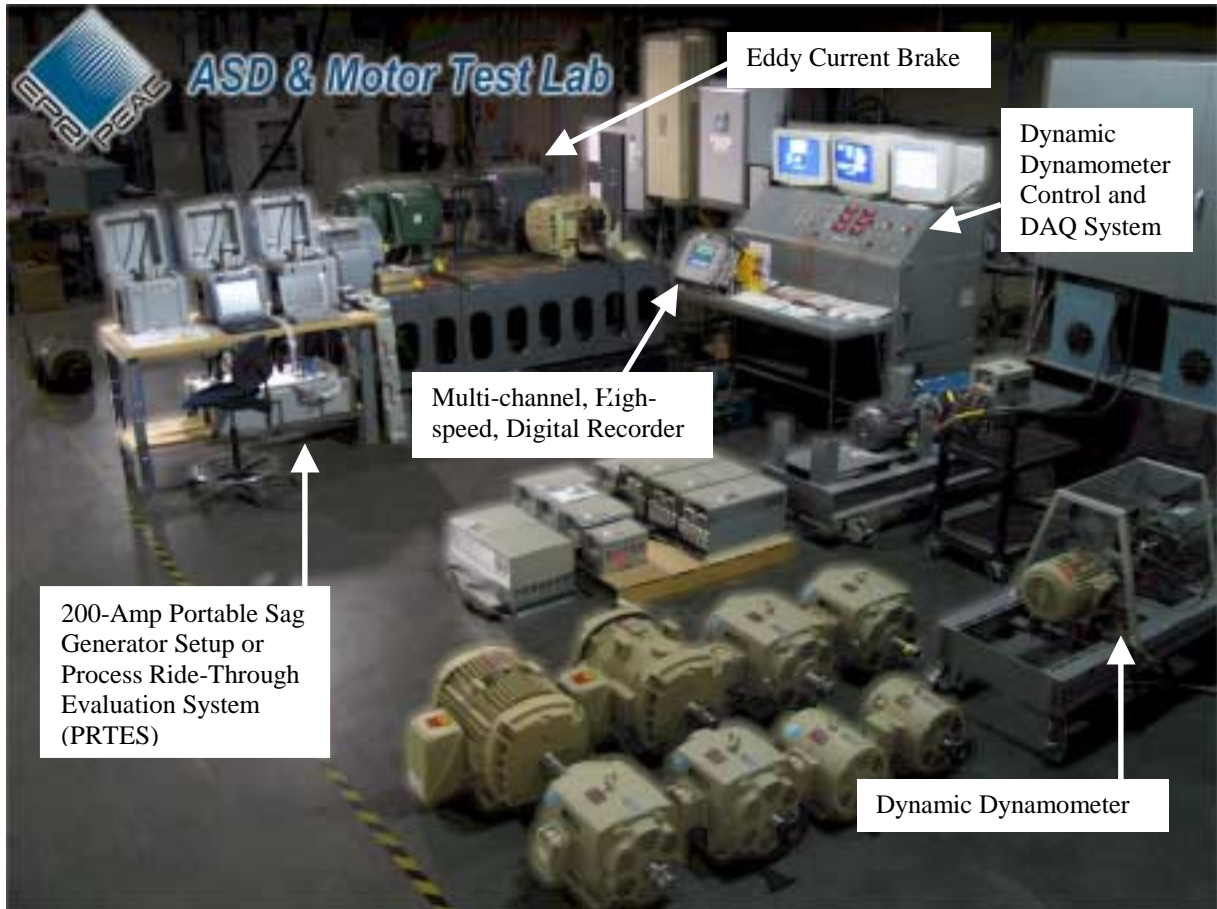

Figure B-3 – Test Facilities

Attachment C - SEMI F47 Abstract

The SEMI F47 “Specification for Semiconductor Processing Equipment Voltage Sag Immunity” document defines the threshold that a semiconductor tool must operate without interruption (per SEMI F42) and it also provides a target for the facility and utility systems. The Recognizing semiconductor factories require high levels of power quality due to the sensitivity of equipment and process controls and that Semiconductor processing equipment is especially vulnerable to voltage sags, this document defines the voltage sag ride-through capability required for semiconductor processing, metrology, and automated test equipment.

The requirements in this international standard were developed to satisfy semiconductor industry needs. While more stringent than existing generic standards, this industry-specific specification is not in conflict with known generic equipment regulations from other regions or generic equipment standards from other organizations. It is the intent of this standard to provide specifications for semiconductor processing equipment that will lead to improved selection criteria for sub-components and improvements in equipment systems design. While it is recognized that in certain extreme cases or for specific functions battery storage devices may be appropriate, it is not the intent of this standard to increase the size or use of battery storage devices provided with equipment. Focus on improvements in equipment component and system design should lead to a reduction or elimination in the use of battery storage devices to achieve equipment reliability during voltage sag events.

The SEMI F47 document specifies the minimum voltage sag ride-through capability design requirements for equipment used in the semiconductor industry. The expected equipment performance capability is shown graphically on a chart representing voltage sag duration and percent deviation of equipment nominal voltage. The primary focus for this specification is semiconductor processing equipment including but not limited to the following tool types:

- Etch equipment (Dry & Wet)
- Film deposition equipment (CVD & PVD)
- Thermal equipment
- Surface prep and clean
- Photolithography equipment (Stepper & Tracks)
- Chemical Mechanical Polishing equipment
- Ion Implant equipment
- Metrology equipment
- Automated test equipment

The actual SEMI F47 ride-through curve is shown below.

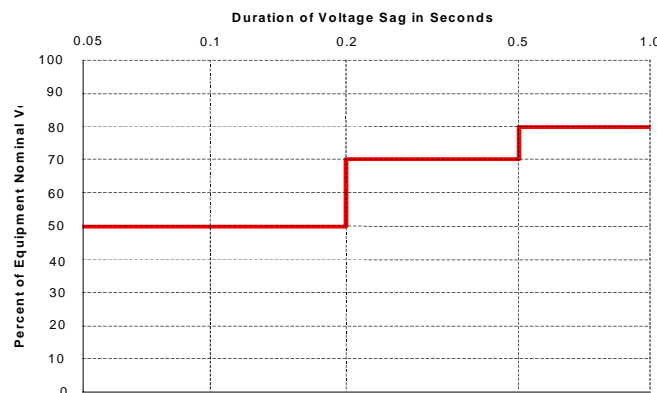

Figure A-1 The SEMI F47 Voltage Sag Ride-Through Curve



The specification states that Semiconductor processing, metrology, and automated test equipment must be designed and built to conform to the voltage sag ride-through capability per the defined curve. Equipment must continue to operate without interrupt (per SEMI E10) during conditions identified in the area above the defined line. In the context of SEMI F47, interrupt means any assist or failure. An assist is defined as an unplanned interruption that occurs during an equipment cycle where all three of the following conditions apply:

- The interrupted equipment cycle is resumed through external intervention (e.g., by an operator or user, either human or host computer).
- There is no replacement of a part, other than specified consumables.
- There is no further variation from specification of equipment operation.

Furthermore, a failure is any unplanned interruption or variance from the specifications of equipment operation other than assists. Although no variation in the tool's process is the goal, this standard addresses these issues as related to the equipment operation only.



The Power of Reliability™

EPRI PEAC Corporation

A Power Quality Engineering Services Company

Attachment D. – Test Protocol for Altivar 58 Series Drives



PROPRIETARY DOCUMENT



**Square D
AC Drives
SEMI F47 Compliance Test Protocol**

Rev. 3

Prepared for:
Frank Bedics
Staff Product Engineer
8001 Highway 64 East
Knightdale, NC 27545-9023
Phone: 919-217-6608
Fax: 919-217-6619
BedicsF@SquareD.com

Prepared by: Alden Wright
EPRI PEAC Corporation

February 30, 2002

**Square D
AC Drives
SEMI F47 Compliance Test Protocol**

Prepared for: Frank Bedics
Staff Product Engineer
8001 Highway 64 East
Knightdale, NC 27545-9023
Phone: 919-217-6608
Fax: 919-217-6619
Email: BedicsF@SquareD.com

Prepared by: Alden Wright
EPRI PEAC Corporation

February 30, 2002



PROPRIETARY DOCUMENT



EPRI PEAC Corporation
A Power Quality Engineering Services Company
942 Corridor Park Blvd
Knoxville, Tennessee 37932 • 865-218-8000

NOTICE

PROPRIETARY NOTICE:

This document, in whole or any part thereof, contains proprietary information, and is intended for the sole use of Square D. Using this document, or any part thereof, is expressly forbidden without prior written approval of Square D.

NON-ENDORSEMENT NOTICE:

The use of data or specifications in this document is not an endorsement of any product. There may be other products from different manufacturers that may be equally acceptable in any given application. The data and specifications are presented for completeness to aid the reader in assessing the presented results.

LEGAL NOTICE:

This report was prepared by the EPRI PEAC Corporation. Neither the EPRI PEAC Corporation, EPRI, members of EPRI, nor any person acting on behalf of any of them: (a) makes any warranty, express or implied, with respect to the use of any information, apparatus, method, or process disclosed in this document; or (b) assumes any liabilities with respect to the use of, or for damages resulting from the use of any information, apparatus, method or process disclosed in this document; or (c) grants any right, title, license, or permission to use any information, apparatus, method, or process described in this document. Use of information, apparatus, method, or process disclosed in this document may infringe privately owned rights.



Table of Contents

List of Tables	4
1. General	5
2. Electrical Requirements	7
2.1 PRTEES Electrical Requirements	7
3.0 Safety Requirements	9
4.0 Man-Power and Schedule Requirements	9
5.0 Tool Testing	10
5.1 General Strategy	10
5.2 Measurements	11
5.2.1 AC Drive Measurement Points	11

List of Tables

Table 1- Square D/Altivar Drive Testing Matrix	5
Table 2- PRTEES Electrical Requirements	6
Table 3- SEMI F47 Test Points	9
Table 4- PRTEES Measurement Points for the AC Drives	10
Table 5 - Phase-to-Phase Voltage Sag Tabular Test Results	11

List of Figures

Figure 1- PRTEES Electrical Hook-up Diagrams	7
Figure 2- Required Semiconductor Equipment Voltage Sag Ride-Through Capability Curve (from SEMI F47)	9

SEMI F47 Compliance Test Plan for Square D AC Drives



1. General

The objectives of the tests are to evaluate the variable frequency AC drives from the Altivar 58 family against SEMI F47 and issue compliance documentation for the units that pass the test.

EPRI PEAC will utilize the Process Ride-Through Evaluation System (PRTES) to produce voltage sags and record the results.

Objectives of Testing:

- To certify drives as F47 Compliant for use in the Semi Conductor industry
- Test to cover all drives and configurations: Variable Torque (VT) with/Without EMC, Constant Torque (CT) with/Without EMC

Drive Configuration:

The drives will be configured with parameters other than the default parameters, that are required to be set when the drives are used in an application that has an F47 compliance requirement.

Drive HP ratings:

All of the drives to be tested (with the exception of the 3hp unit) have different Horsepower ratings when configured for Constant Torque or Variable Torque applications. When equipped with EMC filtering, the drives use the Constant Torque rating.

**SEMI F47 Compliance Test Plan for
Square D AC Drives**



Table 1. Square D Altivar Drive Testing Matrix

Test Designator	Model#	Version	Specs	HP VT	HP CT
SD_ASD1_50	ATV58HU72N4ZU	V3.1 IE14	4kW/ 5HP - 400/460V - 50/60Hz	7.5	5
SD_ASD2_50	ATV58HU90N4ZU	V3.1 IE14	5.5kW/ 7.5HP - 400/460V - 50/60Hz	10	7.5
SD_ASD3_50	ATV58HD12N4ZX	V3.1 IE14	7.5kW/ 10HP - 400/460V - 50/60Hz	15	10
SD_ASD4_50	ATV58HD16N4ZX	V3.1 IE14	11kW/ 15HP - 400/460V - 50/60Hz	20	15
SD_ASD5_50	ATV58HD 23N4ZX	V3.1 IE14	15kW/ 20HP - 400/460V - 50/60Hz	25	20
SD_ASD6_50	ATV58HD 23N4ZX	V4.1 IE25	15kW/ 20HP - 400/460V - 50/60Hz	25	20
SD_ASD7_50	ATV58HD28N4XZX	V3.1 IE14	18.5kW/ 25HP - 400/460V - 50/60Hz	30	25
SD_ASD8_50	ATV58HD33N4XZX	V4.1 IE25	22kW/ 30HP - 400/460V - 50/60Hz	40	30
SD_ASD9_50	ATV58HD46N4XZX	V3.1 IE14	30kW/ 40HP - 400/460V - 50/60Hz	50	40
SD_ASD10_50	ATV58HD54N4XZ	V4.1 IE25	37kW/ 50HP - 400/460V - 50/60Hz	60	50
SD_ASD1_60	ATV58HU72N4ZU	V3.1 IE14	4kW/ 5HP - 400/460V - 50/60Hz		

Table Notes:

- 1.0 U41 & U54 drives – If other similar drives (U72 to D23) passed F47 testing, therefore, these two drives would be expected to pass in a similar manner. Such will be noted in compliance documentation
- 2.0 HU72, 90, HD12 & 16 – These drives will be supplied with EMC filtering and tested at both Constant Torque (CT) rating and Variable Torque (VT) rating so that both VT and CT ratings are covered in the certification of the drives.
- 3.0 HD23 N4 – This drive is in the middle of the range of drives. Square D will supply one drive with EMC filtering and one drive without EMC filtering. Separate tests would be run to see if there is any appreciable difference between the EMC / Non EMC Drives. If there is no difference, EPRI PEAC will extrapolate that information across the complete range of drives to draw the conclusion that the drives ride through with or without EMC filtering.
- 4.0 HD28, 33, 46 & 54 – Drives will be supplied without EMC filtering, tested with VT since this is the limitation of EPRI PEAC’s test capability at these load levels. At rated load and speed (50 or 60 Hz) in a VT configuration, the test results are expected to be similar to CT. The certification will note that the tests were done at VT and will state that at rated load and speed the same results are expected for CT applications.
- 5.0 HD64 & 79 – Based on these drives being similar to all others, certification of these drives will be based on the results of the other units tested and the expected response.

Assumptions:

1. Tests will be conducted at the expected worst case scenario in order to limit the number of tests that will be required. The basic test set up will involve:
 - i. Drive running at rated speed
 - ii. Drive loaded to rated torque

SEMI F47 Compliance Test Plan for Square D AC Drives



- iii. Test voltage set at 400Vac, 3-phase
- iv. Test frequency will be set at 50Hz

Testing Focus:

- Evaluate Drives to characterize voltage sag ride-through at worst case scenarios
- Compare Results to SEMI F47 Standard. In order to pass SEMI F47, the drive(s) will need to continue operating without interrupt. In context with the response of the drive(s), they should catch the spinning motor and continue operating after the voltage sag event.

2. Electrical Requirements

2.1 PRTES Electrical Requirements

The portable sag generator, also known as the Power Ride-Through Evaluation System (PRTES) electrical requirements are detailed in Table 2:

Table 2. – PRTES Electrical Requirements

PRTES Component	Electrical Requirement
Portable Computer	120Vac outlet <1amp/battery power
Solid State Switch/Contactor Box w/ Data Acquisition & Digital I/O Control Hardware	120 Vac outlet <3amps
Variac Voltage Source	Switched into the circuit during the voltage sag, the device will accept voltages up to 480Vac, 3 phase referenced to ground or neutral. *The variacs are limited to 100A/phase.

*Note: If PRTES uses the ground as a reference instead of a neutral, the ground must be connected to the service entrance ground. The maximum voltage allowable phase-ground is 277Vac.

Three phase power is connected through the PRTES and passed to the electrical load as shown in Figure 1 for the two conditions, constant torque (CT) and variable torque (VT).

SEMI F47 Compliance Test Plan for Square D AC Drives

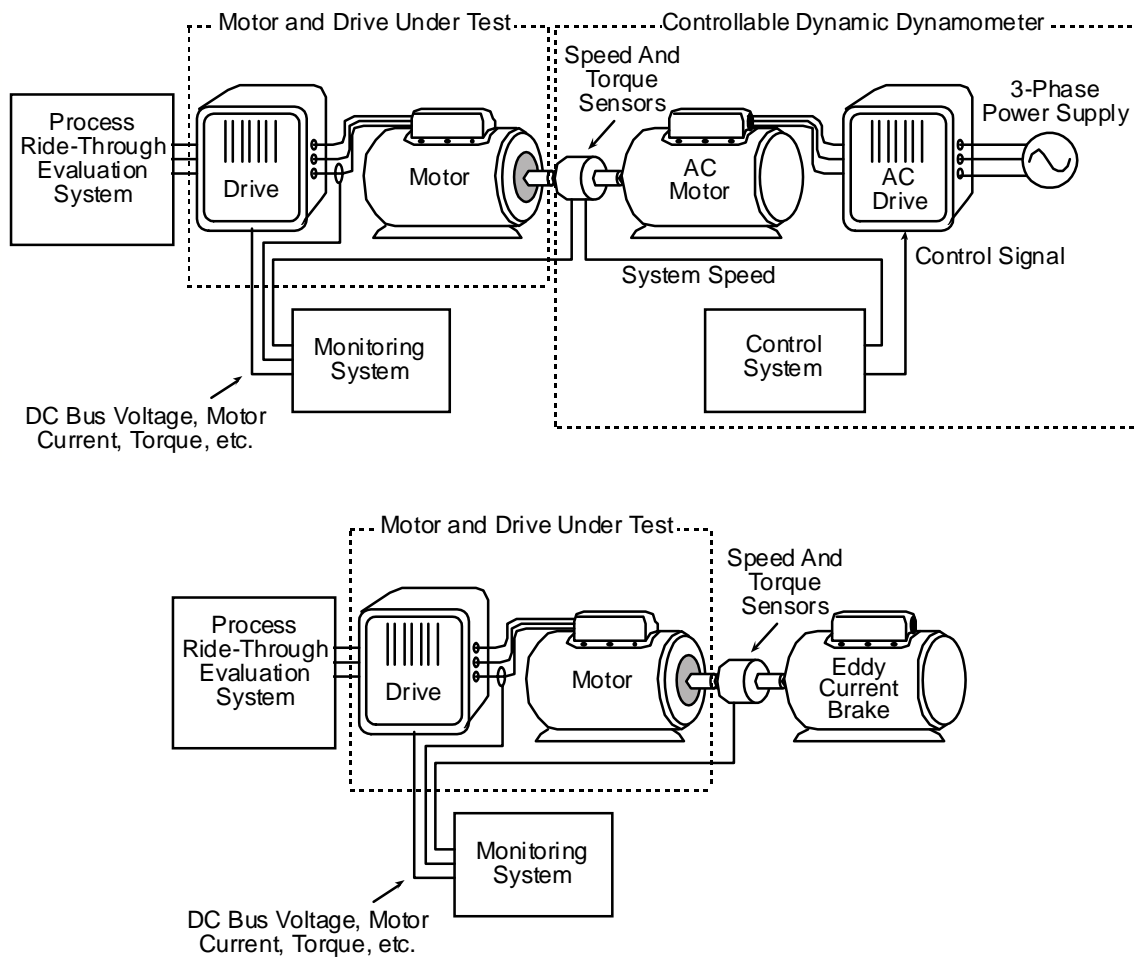

Figure 1. – PRTES Electrical Hook-up Diagrams

The PRTES will be wired in series with the existing fusing or circuit breakers.

Two-phase voltage sags will be injected into the drives at varying depths and durations by switching in the variacs for a set time period. In order to monitor the status of the drives during the injected voltage sag, some of the data acquisition channels will be connected to various connections of the drive.

SEMI F47 Compliance Test Plan for Square D AC Drives



3.0 Safety Requirements

EPRI PEAC will work with the client to follow their safety standards. Usual EPRI PEAC safety procedures are as follows:

- Lock, tag, and try procedures will be followed when the testing is conducted. No circuit shall be connected or wired when electricity is present unless rubber insulated gloves are worn.
- The immediately area surrounding the tool will be corded off and signs reading “Test In Progress” will be attached to the cord.
- Safety Glasses or side-shields for those with prescription glasses will be worn at all times.
- To reduce the chance of accidents, only essential personnel will be allowed within the corded test area.
- Work will be done in an orderly fashion as described in the test protocol. Circuits will be visually inspected before power is restored.

4.0 Man-Power and Schedule Requirements

In conducting the tests, the following personnel will be present:

Power Quality Engineer – Alden Wright
PRTES Technician – Tom Cooke

The testing is scheduled to be completed by April 3rd, 2002.

SEMI F47 Compliance Test Plan for Square D AC Drives



5.0 Tool Testing

The tool testing will be done according to the SEMI F42 test methodology.

5.1 General Strategy

The general strategy for the AC Drive testing is to characterize the drives with out any power conditioning in place. A voltage sag ride-through tolerance curve will be developed for the overall tool from this testing. The tool will be tested at various voltage levels and durations to characterize the ability of the equipment to ride-through voltage sags. Table 3 lists points defined in SEMI F47. Single-phase and two-phase voltage sags will be performed according to SEMI F42 test protocol.

Table 3. – SEMI F47 Test Points

Test No.	Sag Duration (60 Hz Cycles)	Sag Duration (Seconds)	SEMI F47 Ride-Through Curve Sag Depth (% Vnominal)
1	60	1.0s	80
2	30	0.5s	80
3	30	0.5s	70
4	12	0.2s	70
5	12	0.2s	50
6	3	.05s	50

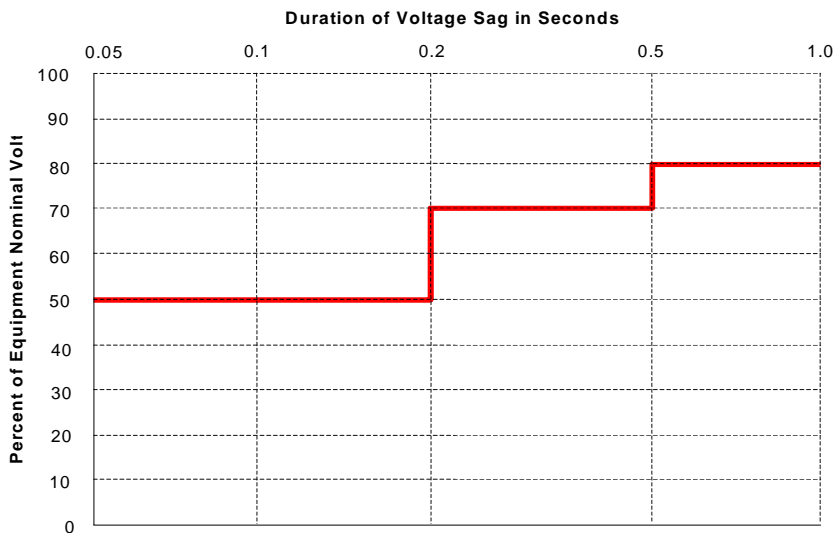

Figure 2. – Required Semiconductor Equipment Voltage Sag Ride-Through Capability Curve (from SEMI F47)

Note: To meet SEMI F47, Equipment must continue to operate without interrupt during voltage sags above the line.

SEMI F47 Compliance Test Plan for Square D AC Drives



5.2 Measurements

The measurement data shown below will be useful during the test and in the process of analyzing the tool. This information will help identify “weak link” components or subsystems of the three Ion Implanters. Measurement need to be made prior to connecting to confirm voltage levels.

5.2.1 AC Drive Measurement Points

Table 4. – PRTES Measurement Points for the AC Drives

Connector, TB, Board	Number	Description	Symbol	PRTES Channel
		Ia, phase A current	Ia	1
		Ib, phase B current	Ib	2
		Ic, phase C current	Ic	3
				4
				5
				6
				7
				8
				9
				10
				11
				12
				13
		Va-n, phase a-n voltage	Va	14
		Vb-n, phase b-n voltage	Vb	15
		Vc-n, phase c-n voltage	Vc	16

Channel 1-8 are limited to +/- 5 V. Differential probes will be used to measure voltages greater than the channel limits.

SEMI F47 Compliance Test Plan for Square D AC Drives



6.0 Voltage Sag Tabular Test Results

The test data will be organized according to Table 5 below.

Table 5. – Phase-to-Phase Voltage Sag Tabular Test Results SquareD AC Drive

SEMI F47 Test - Adjustable Speed Drive Data Sheet											
Test Designator:		SD ASD1 50					Notes:				
Model:											
Specs:		XkW/XHP - 400/460 - 50/60Hz									
Nom. Voltage:		400Vab, 400Vbc, 400Vca									
Nom. Speed (rpm):		xxxx CT		xxxx VT							
Freq.(Hz)		50									
Date:											
Tester:		Thomas Cooke, PQ Tech									
Duration			Constant Torque(5hp)				Variable Torque(7.5hp)				
Seconds	Cycles 50Hz	SEMI F47 Standard Test Points (phase-to-phase)	Min. Speed (rpm)	Min. Speed % of Nom.	Automatic Restart	Speed Remain above 95%	Min. Speed (rpm)	Min. Speed % of Nom.	Automatic Restart	Speed Remain above 95%	
1	50.0	80%	xxxx	xxxx	Yes/No	Yes/No	xxxx	xxxx	Yes/No	Yes/No	
0.5	25.0	70%	xxxx	xxxx	Yes/No	Yes/No	xxxx	xxxx	Yes/No	Yes/No	
0.2	10.0	65%	xxxx	xxxx	Yes/No	Yes/No	xxxx	xxxx	Yes/No	Yes/No	
0.2	10.0	60%	xxxx	xxxx	Yes/No	Yes/No	xxxx	xxxx	Yes/No	Yes/No	
0.2	10.0	55%	xxxx	xxxx	Yes/No	Yes/No	xxxx	xxxx	Yes/No	Yes/No	
0.2	10.0	50%	xxxx	xxxx	Yes/No	Yes/No	xxxx	xxxx	Yes/No	Yes/No	
0.05	2.5	50%	xxxx	xxxx	Yes/No	Yes/No	xxxx	xxxx	Yes/No	Yes/No	

SEMI F47 Compliance Test Plan for Square D AC Drives



Graphs illustrate the real-time effects of voltage sags on bus voltage and motor speed:

Test Condition
50% phase-to-phase
for 2.5 Cycles (at
50Hz)

50%-2.5
Contant Torque (5hp)

Drive Full Load
Horse Power at either
Constant Torque or
Variable Torque

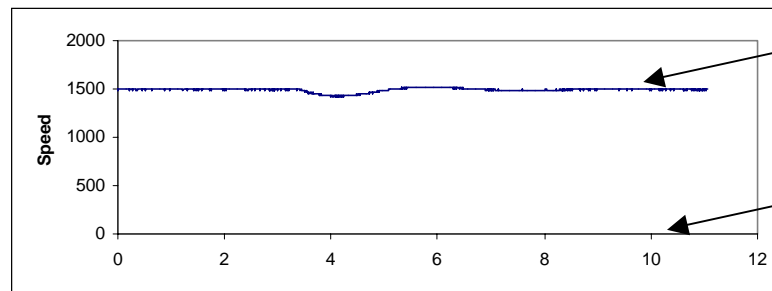
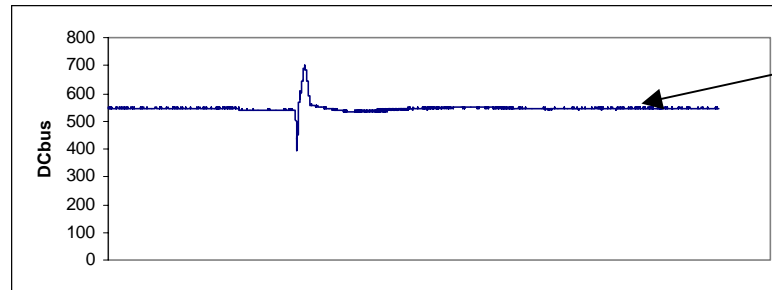
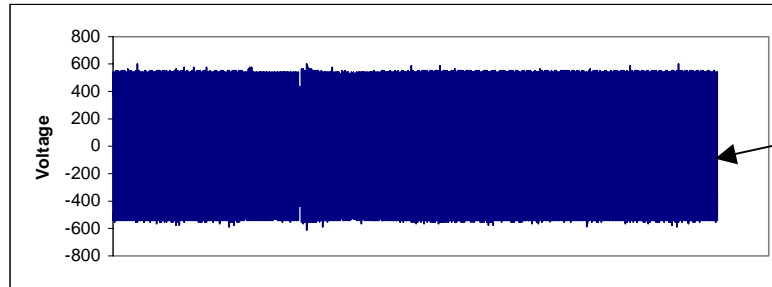



The Power of Reliability™

EPRI PEAC Corporation

A Power Quality Engineering Services Company



EPRI PEAC Corporation PQ StarSM Certification for the Semiconductor Industry

Having conducted power quality tests on hundreds of devices and electrical equipment since 1992, EPRI PEAC Corporation is known worldwide for power quality testing expertise. Since April 1997, EPRI PEAC has conducted voltage sag testing on over 54 semiconductor processing tools. In order to serve the semiconductor industry, EPRI PEAC Corporation has established a certification program to test manufacturer equipment per established power quality standards. PQ StarSM certification for the SEMI F47 standard (Specification for semiconductor Processing Equipment Voltage Sag Immunity) is now available for semiconductor equipment suppliers. EPRI PEAC utilizes the SEMI F42 test standard (Test Method for Semiconductor Processing Equipment Voltage Sag Immunity). With the PQ Star certification, EPRI PEAC Corporation offers a third party verification that the equipment tested meets this important new power quality standard.

For more information about the PQ StarSM test program for the semiconductor industry or inquire about testing, contact Mark Stephens at mstephens@epri-peac.com

EPRI PEAC Corporation
942 Corridor Park Blvd
Knoxville, Tennessee 37932
(865)218-8000
www.f47testing.com