

Modicon® solution helps City of Hamilton clean more water

Utility – Water/Wastewater
City of Hamilton
www.hamilton-city.org/pw/wwtp



UNITED STATES

The application

The city-owned City of Hamilton wastewater treatment facility in Hamilton, Ohio, serves 63,000 residential and commercial customers, in addition to providing full treatment service for one major paper mill and secondary treatment for a second paper mill. The two paper mills produce approximately 60% of the facility's total flow.



The City of Hamilton treatment facility.

This plant treats an average of 22 million gallons of wastewater per day, with a capacity for peak flows of 62 million gallons. The majority of the sludge produced at this plant is processed into reusable compost at an onsite, state-of-the-art composting facility. Approximately 24 hours after wastewater enters the facility, cleaned and treated water leaves the plant and is introduced into the Great Miami river.

The previously installed relay-based control system also included one SY/MAX PLC without networking. Built in 1958, the plant uses General Electric and Westinghouse motor control centers. The City of Hamilton needed not only to update the old equipment, but to add capacity.

Merlin Gerin

Modicon

Square D

Telemecanique



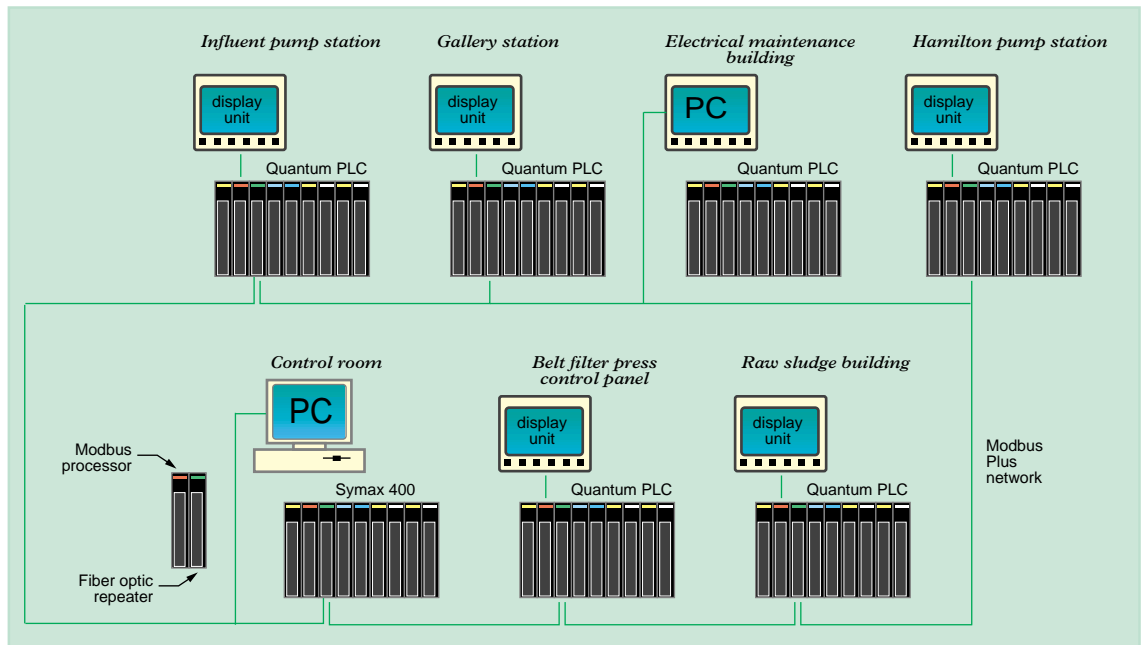

The control system block diagram



PLC panels such as these form a network that provides the backbone for plant-wide alarming and troubleshooting capabilities.



Objective

In the course of replacing the existing equipment, City of Hamilton sought to:

- provide better data acquisition and control capabilities,
- improve system reliability,
- enhance system troubleshooting capabilities, and
- increase treatment capacity, but not employee requirements.

This plant expansion was installed without shutting down the existing process. The plant meets NPDES permits.

Solution

Schneider Electric provided a complete power and automation solution, including local support, training, and start-up for the PLCs, drives and power monitoring system. The process control solution is a coordinated effort among numerous parties: City of Hamilton; Burgess & Niple, consulting engineer; Dublin Controls, system integrator; and Schneider Electric (Square D and Modicon products).

The Modicon Quantum™ PLC communicates via a fiber optic Modbus Plus network. This network provides the backbone for plant-wide alarming and troubleshooting capabilities. The five PLCs control the ATV 66 drives via hard-wired analog signals and monitor the drives' status via the Modbus Plus network. The man-machine interface is provided by Panelmate 4000 stainless steel units.

The treatment process was maintained while the old equipment was decommissioned and the new system placed on-line.

Customer benefit

Measurable benefits include an increased treatment capacity of an estimated maximum flow of 62 million gallons per day (up from the original 32 million gallons). The bulk of this added capacity is dedicated to handling peak wet weather flows through the plant and thus eliminating raw wastewater overflows in the City's sewage collection system. The increased reliability of this system serves to better protect the environment.